



Heavy Duty Slider Bed Conveyors HSC .

The synthetic belt slides over a solid stationary bed. HSC Conveyors are low cost heavy duty conveyors capable of transporting medium loads (20-50 Kg/m) over distances of up to 30 meters. They can be manufactured in Stainless Steel , and fitted with FDA approved belting and can be floor mounted, suspended from ceilings using hangers, or wall mounted using brackets .

سيور منزلقة على الواح HSC .

تستخدم للأحمال المتوسطة من ٢٠ الى ٥٠ كجم/متر طولي لمسافات تصل الى ٣٠ متر حيث تنزلق الحوائط على الواح من الصلب كما يمكن ان تصنع من صلب لا يصدأ للأغراض الصحية والغذائية. يمكن ايضا تحميلها على ارجل ارضية او كوابيل حوائط او تعليقها من الاسقف.

Factory :New Borg El Arab 2nd Zone
entrance 2c street 3 - entrance 2c street 5
Tel:+20-(03)-4624127 - 4624126 - 4624025
fax : (03) 4624291

Cairo Office : Corniche El Nile, Maadi, Cairo
Tel +20:(0)2-25266333
Fax +20:(0)2-25264888

Info@UnitelEgypt.com

Sales@UnitelEgypt.com



www.UnitelEgypt.com



/UnitelEgypt

HSC Heavy Duty Slider Bed Conveyor

Features

This type of conveyor is a general purpose conveyor where the synthetic belt slides over a solid stationary bed. The sheet metal construction of this conveyor is rigid and offers a stable chassis on which head and tail pulleys are mounted.



Characteristics

The HSC family of conveyors accepts many accessories which makes it a very flexible and versatile building block.

It can be fitted with hoppers, chutes, belt troughing attachments, side tables, inverters for variable belt speed. The belts can be standard PVC types, food grade types, cleated with corrugated sides for steep angle elevators, or grip-face type for inclined applications.



This family is compatible with the Gravity Roller Conveyor family RLG.

Applications

HSC Conveyors are low cost heavy duty conveyors capable of transporting medium loads (20-50 Kg/m) over distances of up to 12 meters.

They are used in general purpose transportation of a great variety of unit goods, of any size and shape, in chemical, engineering, food, process, and pharmaceutical industries.



HSC conveyors can also be manufactured in Stainless Steel for applications in food processing, or wet environment, and fitted with FDA approved belting.

HSC conveyors can be floor mounted, suspended from ceilings using hangers, or wall mounted using brackets

HSC Heavy Duty Slider Bed Conveyor

Specifications

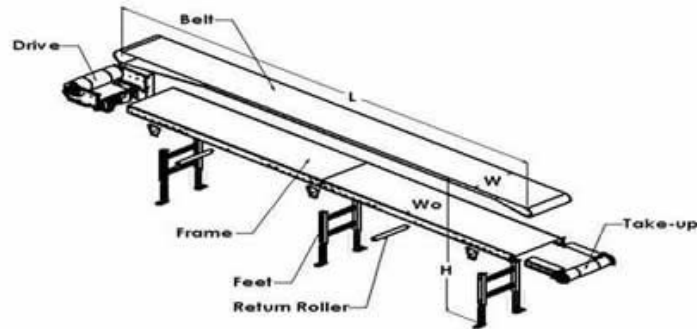

Loading Capacity	200 to 500 N/m
Head Pulley Diameter	Ø168
Take Up Pulley Diameter	Ø100 , 168
Return Rollers Diameter	Ø50
Return Rollers Pitch	1215 , 2430 mm
Linear Speed	Sprocket driven 18, 23, 28, direct drive 28,33, m/min
Mains Supply	380VAC 50 Hz 3phase
Motor Power	Calculated based upon belt loading and conveyor length
Motor Class	IP54
Insulation Class	IP54
Belt Materials	PVC , PU, Cleated
Take-up Distance	120mm
Paint	Electrostatic Epoxy Powder RAL 7035

Dimensions

Standard Width (W) / Preferred Values

Outer Distance (Wo)

W	300	400	500	600	700	800
Wo	386	486	586	686	786	886

Standard Section Length : 2430

Options : intermediate lengths available (in 90 mm increments only)

Modules are attached together using Butt Couplings, to obtain any desired length.

HSC Heavy Duty Slider Bed Conveyor

Options

Floor Supports	SGL		
Ceiling Hangers	Yes		
Wall Mount	Yes	Overhead Drive	Yes
Head pulley lagging	Yes	Left or Right Side Drive	Yes
V-Belt Underside Guide	Yes	Brake Motor	Yes
Grip Face Belt Material	Yes	Bidirectional motion	Yes
Cleated Belts	Yes	Variable Speed Drives	Yes
Corrugated Belt Sides	Yes	Stainless Steel Construction	Yes
Accumulation Belt Material (PU)	Yes		

Accessories

Long-span Under-Trussing	Yes	Inside scraper	Yes
Cross Bracing	Yes	Outside Scrapers	Yes
Butt Coupling	Yes	Emergency Pull Cord	Yes
Nose Wheel	Yes	Brake Rollers	No
Front Bumper	Yes		
Tail Bumper	Yes		
End Stops	Yes	Troughing Attachment.	Yes
Deflector	Yes	Optical Switches and Controls	Yes
Drip Pan	Yes		
Chutes	No	Push Button Station	Yes
Guard Rails	Yes	Pushers	Yes
Side Skirts	Yes	Back Stops	No
Feed (Tail end) Hopper	Yes		
Delivery (Head end) Hopper	Yes	Longitudinal Side Tables	Yes
Head Pulley Hood	No	Individual Side Tables	Yes

مكتب القاهرة : برج القاتوينين كورنيش المعادى
تليفون : ٠٢/٢٥٢٦٦٣٣٣
فاكس : ٠٢/٢٥٢٦٤٨٨٨

مدينة برج العرب الجديدة - المنطقة الصناعية الثانية
يونيتل/ مدخل ٢ شارع ٣ - مدخل ٢ شارع ٥
تليفون : ٠٣/٤٦٢٤٤٢٤-٤٦٢٤٠٢٥-٤٦٢٤١٢٦-٤٦٢٤١٢٧
فاكس : ٠٣/٤٦٢٤٢٩١



www.UnitelEgypt.com

[f](#) [You Tube](#) [/UnitelEgypt](#)

Sales@UnitelEgypt.com

Info@UnitelEgypt.com